

G9SP Ethernet IP Communication to Omron's NJ5 PLC's

Rev1.0

Mike Wash

This document will walk you through a step by step setup for communication from a G9SP to a Omron's NJ5 PLC using Ethernet IP communications. This communication link is used to communicate status of the safety controller as well as to provide signals from the PLC to the safety controller for resetting circuits, ect.

Example code for this presentation can be opened using Omron's Network Configurator for Safety Devices.

File Name

G9SP_Ethernet_IP_NJ5_Exsample_Rev1.nfc

Overview of G9SP Ethernet IP

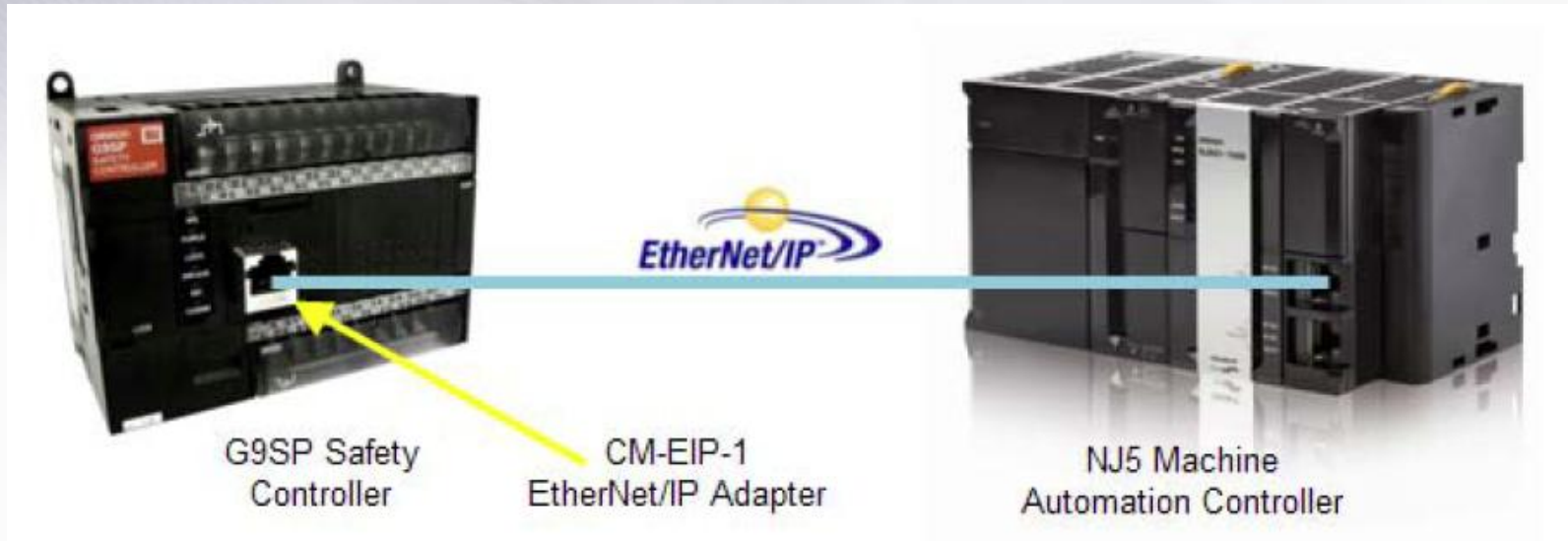

The process of configuring the NJ5 to G9SP EtherNet/IP communications can be broken down into several steps. These steps are as follows:

1. Install the CM-EIP-1 EtherNet/IP adapter in the G9SP and set the IP address.
2. Set the IP Address for the EtherNet/IP port on the NJ5 MAC.
3. Create tags in the NJ5 that can be used to establish communications.
4. Install the G9SP EDS file in the EtherNet/IP configurator.
5. Configure the EtherNet/IP connection using the EtherNet/IP Configurator and create a program in the NJ5.

Each of these steps will be discussed in detail on the following pages.

Overview of G9SP Ethernet IP

Step 1 – Install the CM-EIP-1 EtherNet/IP adapter in the G9SP and set the IP address.

1. Plug the CM-EIP-1 EtherNet/IP adapter into the G9SP as shown below:
2. The adapter defaults to an IP Address of 192.168.250.1 out of the box, so it will be necessary to set your PC to an IP address on the same network to perform the initial setup of the device (192.168.250.2 for example).
3. Once you have manually set your PC's IP Address to 192.168.250.2, you can open up Internet Explorer (or other compatible browser) to configure the IP Address of the adapter.
4. Type <http://192.168.250.1> into the browser URL window. The following screen will appear:



Omron CM-EIP-1 Configuration - Windows Inter

http://192.168.250.1/

File Edit View Favorites Tools Help

★ Favorites ☆

Omron CM-EIP-1 Configuration

CM-EIP-1 Configuration

IP Address:	<input type="text" value="192.168.250.1"/>
Subnet Mask:	<input type="text" value="255.255.255.0"/>
Gateway:	<input type="text" value="0.0.0.0"/>

G9SP Ethernet IP Adapter Setup

5. Type the desired IP Address in the IP Address field as well as the desired Subnet Mask and gateway. The information for this example is shown below:
6. Once the settings have been made as desired, press the “apply setting” button. Communications will be lost when the address is changed. It is necessary to change your PC IP Address to communicate with the adapter further.

For the setting to take affect, reboot the G9SP safety controller after changing the IP address through the web page interface

Note: The IP address for the CM-EIP-1 cannot be configured from within the G9SP Configurator. The configuration section is only for Ethernet for the FINS Ethernet Adapter CP1W-CIG41

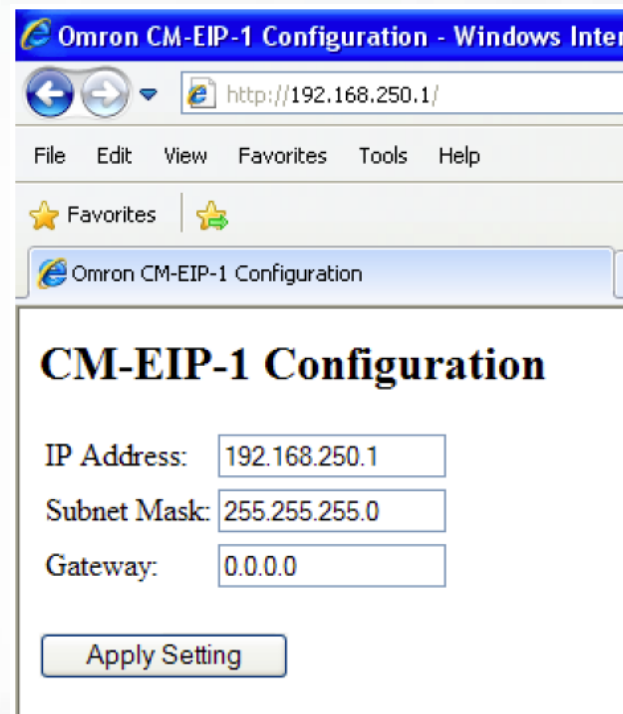

Omron CM-EIP-1 Configuration - Windows Inter

http://192.168.250.1/

File Edit View Favorites Tools Help

★ Favorites ★

Omron CM-EIP-1 Configuration

CM-EIP-1 Configuration

IP Address:

Subnet Mask:

Gateway:

At this point, the Ethernet/IP adapter is installed and the IP address is configured. You can then connect the G9SP to the Ethernet/IP port on the NJ5 controller.

NJ5 MAC Ethernet IP Adapter Setup

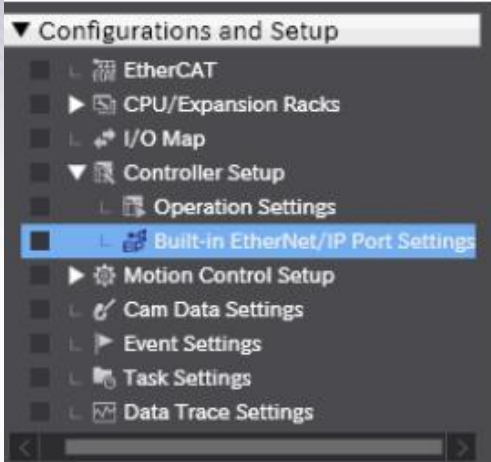

- Open the Sysmac Studio programming software and either open the project associated with the machine or create a new one.
- Double click on **Built-in Ethernet/IP Port setting** option under **Configurations and Setup** as shown

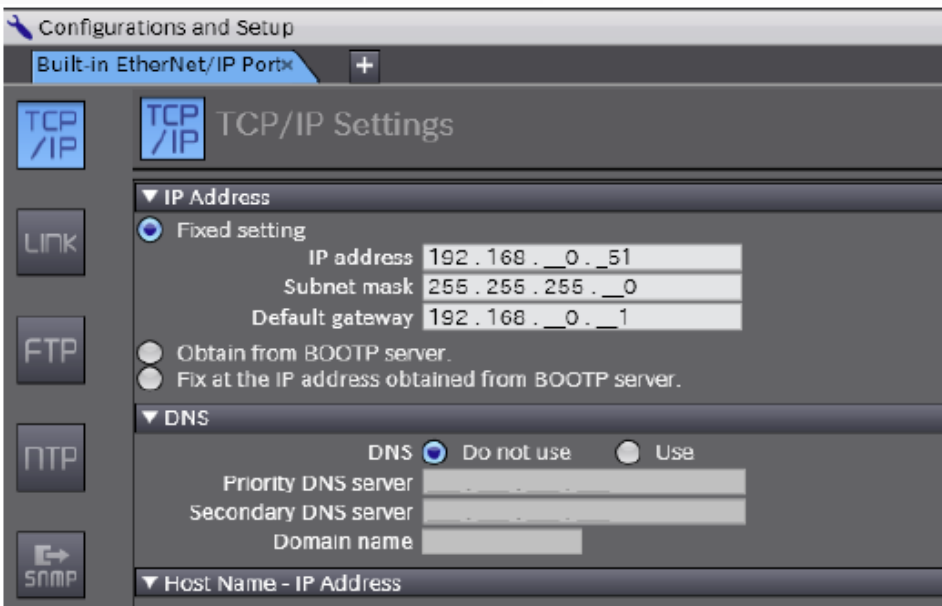

- This window will appear
- Make the appropriate IP address setting in this window. In this example we will use these setting

NJ5 Down-load IP setting

4. Physically connect your PC to the NJ5 MAC using a USB cable.
5. Choose the Communications Setup option from the Controller pulldown menu.
6. Choose the Direct Connection via USB option and then press OK.
7. Connect to the NJ5 MAC by choosing the Controller pulldown menu and then Online.
8. Once the software is online with the NJ5 MAC, perform a synchronization by choosing Synchronization from the Controller pulldown menu.
9. Press the Transfer to Controller option (make sure that the current program has been uploaded from the NJ5 MAC prior to doing this step or you will be downloading new code into the controller).



The IP Address of the NJ5 MAC is now configured for the application.

Data Exchange With A G9SP



There are 2 assemblies that Produce data from the G9SP to the PLC. The user can select which assembly is used at the time the connection to the G9SP is configured. Consult the G9SP Operation Manual (Z922) for a definition of the data in the assemblies. Note: The order of the data from the CM-EIP-1 is **not** identical to that shown in Omron manual Z922 for serial or FINS Ethernet communications.

Assembly 100

Bytes	Data
0 + 1	Optional Comms Transmission Data
2 + 3	Optional Comms Transmission Data
4 + 5	Safety Input Terminal Data Flags
6 + 7	Safety Input Terminal Data Flags
8 + 9	Safety Input Terminal Data Flags
10 + 11	Safety Output Terminal Data Flags
12 + 13	Safety Output Terminal Data Flags
14 + 15	Safety Input Terminal Status Flags
16 + 17	Safety Input Terminal Status Flags
18 + 19	Safety Input Terminal Status Flags
20 + 21	Safety Output Terminal Status Flags
22 + 23	Safety Output Terminal Status Flags
24 + 25	Safety Input Terminal Error Causes
26 + 27	Safety Input Terminal Error Causes
28 + 29	Safety Input Terminal Error Causes
30 + 31	Safety Input Terminal Error Causes
32 + 33	Safety Input Terminal Error Causes
34 + 35	Safety Input Terminal Error Causes
36 + 37	Safety Input Terminal Error Causes
38 + 39	Safety Input Terminal Error Causes
40 + 41	Safety Input Terminal Error Causes
42 + 43	Safety Input Terminal Error Causes
44 + 45	Safety Input Terminal Error Causes
46 + 47	Safety Input Terminal Error Causes
48 + 49	Safety Output Terminal Error Causes
50 + 51	Safety Output Terminal Error Causes
52 + 53	Safety Output Terminal Error Causes
54 + 55	Safety Output Terminal Error Causes
56 + 57	Safety Output Terminal Error Causes
58 + 59	Safety Output Terminal Error Causes
60 + 61	Safety Output Terminal Error Causes
62 + 63	Safety Output Terminal Error Causes
64 + 65	Unit Status
66 + 67	Communications Status

Assembly 102

Bytes	Data
0 + 1	Optional Comms Transmission Data
2 + 3	Optional Comms Transmission Data
4 + 5	Safety Input Terminal Data Flags
6 + 7	Safety Input Terminal Data Flags
8 + 9	Safety Input Terminal Data Flags
10 + 11	Safety Output Terminal Data Flags
12 + 13	Safety Output Terminal Data Flags
14 + 15	Safety Input Terminal Status Flags
16 + 17	Safety Input Terminal Status Flags
18 + 19	Safety Input Terminal Status Flags
20 + 21	Safety Output Terminal Status Flags
22 + 23	Safety Output Terminal Status Flags
24 + 25	Unit Status
26 + 27	Communications Status

Consumed Assembly

Bytes	Data
0 + 1	Optional Communications Reception Data
2 + 3	Optional Communications Reception Data
4 + 5	Reserved

Bit layout of the Optional Communications Transmission Data

Byte	Bit 7	Bit 6	Bit 5	Bit 4	Bit 3	Bit 2	Bit 1	Bit 0
0	OCTD 07	OCTD 06	OCTD 05	OCTD 04	OCTD 03	OCTD 02	OCTD 01	OCTD 00
1	OCTD 15	OCTD 14	OCTD 13	OCTD 12	OCTD 11	OCTD 10	OCTD 09	OCTD 08
2	OCTD 23	OCTD 22	OCTD 21	OCTD 20	OCTD 19	OCTD 18	OCTD 17	OCTD 16
3	OCTD 31	OCTD 30	OCTD 29	OCTD 28	OCTD 27	OCTD 26	OCTD 25	OCTD 24

Data Exchange With A G9SP



The Optional Communications Transmission Data bits correspond to the Optional Communications Transmission Data bits in the G9SP configurator as shown below.

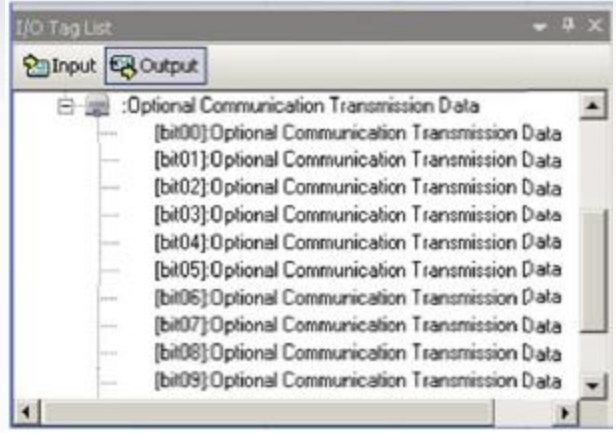

5.2 Consumed Data:

There is 1 assembly that Consumes data from the PLC into the G9SP. The only data consumed by the G9SP is the 32 bits of Optional Communications Reception Data.

Bytes	Data
0 + 1	Optional Communications Reception Data
2 + 3	Optional Communications Reception Data
4 + 5	Reserved

Unit Status: The G9SP Unit Status will be stored in bytes 24 and 25 for assembly 102, and bytes 64 and 65 for assembly 100. The data format is shown below.

Byte	Bit 7	Bit 6	Bit 5	Bit 4	Bit 3	Bit 2	Bit 1	Bit 0
24 or 64	Reserved	Reserved	Reserved	Reserved	Reserved	Reserved	Reserved	Unit OK
25 or 65	Reserved	Reserved	FB Error	Reserved	Reserved	Safety Term Err	Output Pwr Err	Reserved

Communications Status: The status of the G9SP to CM-EIP-1 communications will be stored in bytes 26 and 27 for assembly 102, and bytes 66 and 67 for assembly 100. Check the value of Byte 26 / 66 before considering the Produced Data to be valid.

Byte	No Comms Errors	Communications Error
26 or 66	01	00
27 or 67	CB	Error Code

Data Exchange With A G9SP



Bit layout of the Optional Communications Reception Data

Byte	Bit 7	Bit 6	Bit 5	Bit 4	Bit 3	Bit 2	Bit 1	Bit 0
0	OCRD 07	OCRD 06	OCRD 05	OCRD 04	OCRD 03	OCRD 02	OCRD 01	OCRD 00
1	OCRD 15	OCRD 14	OCRD 13	OCRD 12	OCRD 11	OCRD 10	OCRD 09	OCRD 08
2	OCRD 23	OCRD 22	OCRD 21	OCRD 20	OCRD 19	OCRD 18	OCRD 17	OCRD 16
3	OCRD 31	OCRD 30	OCRD 29	OCRD 28	OCRD 27	OCRD 26	OCRD 25	OCRD 24

The Optional Communications Reception Data bits correspond to the Optional Communications Reception Data bits in the G9SP configurator as shown below.

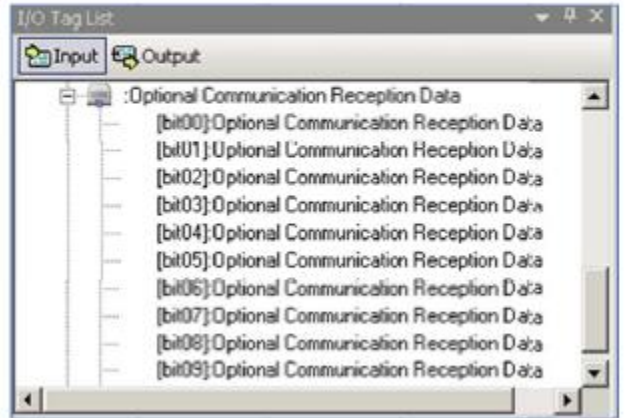

Section 6: Application Heartbeat

An option that many users may find useful is a user created heartbeat signal. This signal would originate from the PLC, transfer to the G9SP, through the logic programming in the G9SP, and back to the PLC. This allows the PLC to easily determine if the entire communications pathway and the associated G9SP program are functioning normally.

A simple Routing Function Block connecting an Optional Communications Reception Data bit to an Optional Communications Transmission bit will accomplish this in the G9SP. The PLC programmer can then pulse the Optional Communication Reception bit, and look for the Optional Communications Reception bit to turn on.

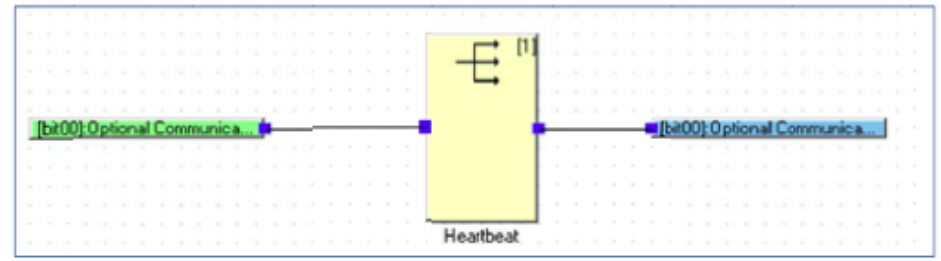

Data Exchange With A G9SP

Section 7: Establishing a Connection with an Omron CJ2: Example

A connection will be established between a G9SP and a CJ2H in the following steps, using the 68 byte Produced assembly.

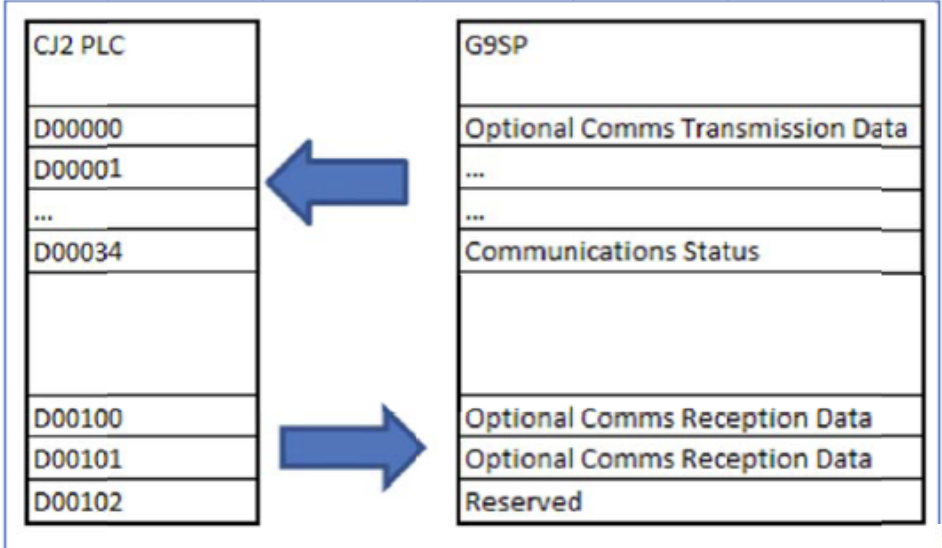

1. Plug the CM-EIP-1 adapter the G9SP, and apply power to the G9SP.
2. Connect the CJ2H, CM-EIP-1, and PC to an Ethernet Switch.
3. Configure the IP address of the CJ2H as 192.168.1.26 using CX Programmer.
4. Configure the IP address of the CM-EIP-1 as 192.168.1.25 through the Web Page interface, as shown previously in **Section 3**.
5. Launch the Network Configurator for EtherNet/IP from **Start / Programs / Omron / CX-One / Network Configurator for EthernetIP / Network Configurator**.
6. Install the .eds file (see Section 2) and the associated icon by clicking the **EDS File / Install** menus, and browsing for the .eds file and the .ico file.

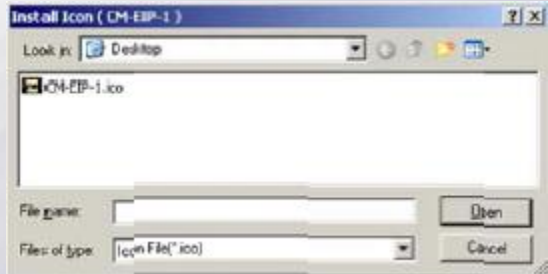
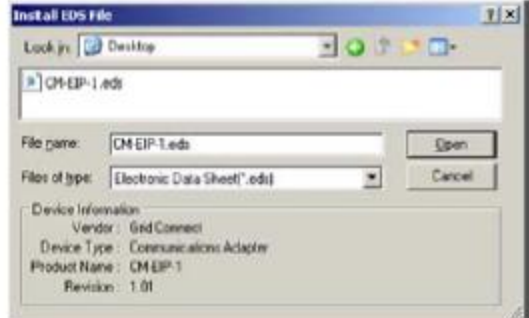

Setting up Tags In NJ5 Controller

The tag created in the NJ5 MAC will be either 68 bytes or 28 bytes depending upon which assembly is chosen for use in the application. In this example, the large assembly will be used. The variable can be created by simply creating a tag that is 68 bytes in size, or the structure that is included with this document can be used as well. In this description, the structure will be used. The consumed assembly is always going to be 6 bytes in length. For more details on the assemblies above, see the G9SP CM-EIP-1 Application setup guide that was included with this quick start.

G9SP Small Produced Structure

G9SP_small_Prod	STRUCT
Optional_Comms	array[0..31] of bool
Safety_input_terminal_data_flags	array[0..47] of bool
Safety_output_terminal_data_flags	array[0..31] of bool
Safety_input_terminal_status_flags	array[0..47] of bool
Safety_output_terminal_status_flags	array[0..31] of bool
Unit_status	array[0..15] of bool
Communication_status	WORD

Copy the boxed in area above and past into the Structures window

G9SP Large Produced Structure

G9SP_large_prod	STRUCT
Optional_Comms	array[0..31] of bool
Safety_input_terminal_data_flags	array[0..47] of bool
Safety_output_terminal_data_flags	array[0..31] of bool
Safety_input_terminal_status_flags	array[0..47] of bool
Safety_output_terminal_status_flags	array[0..31] of bool
Safety_input_terminal_error_causes	array[0..11] of word
Safety_output_terminal_error_causes	array[0..7] of word
Unit_status	array[0..15] of bool
Communication_status	WORD

Copy the boxed in area above and past into the Structures window

Note: Choose the small or the large produce structure depending on which assembly type is used (28 byte or 68 byte)

G9SP Consumed Structure

G9SP_Consume	STRUCT
Optional_Comms	array[0..31] of bool
Reserved	array[0..15] of bool

Copy the boxed in area above and past into the Structures window

The first step in creating the tags to use for the application is to bring in the structure necessary to support the tag creation. Open the provided Excel Spreadsheet and copy the G9SP Large Produced Structure area as shown

Setting up Tags In NJ5 Controller

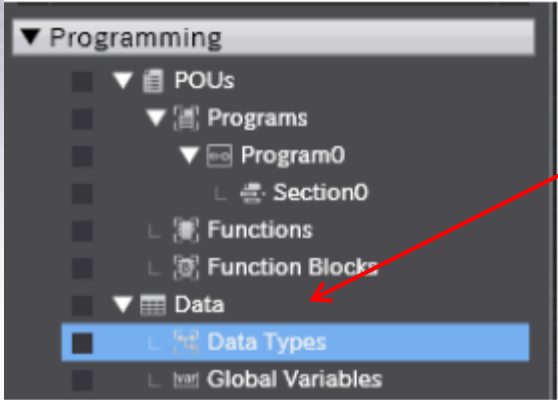

- Return to the Sysmac Studio programming software and double click on **Data Types** in the project workspace

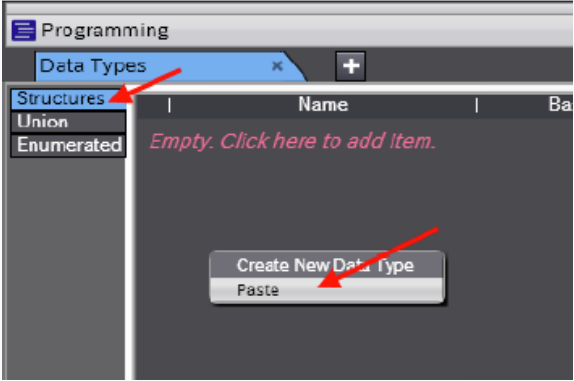

- With the **Structure** option chosen, **Right Click** in the window and choose the paste option.

- The G9SP_large_prod structure will now show as available in the list of structures

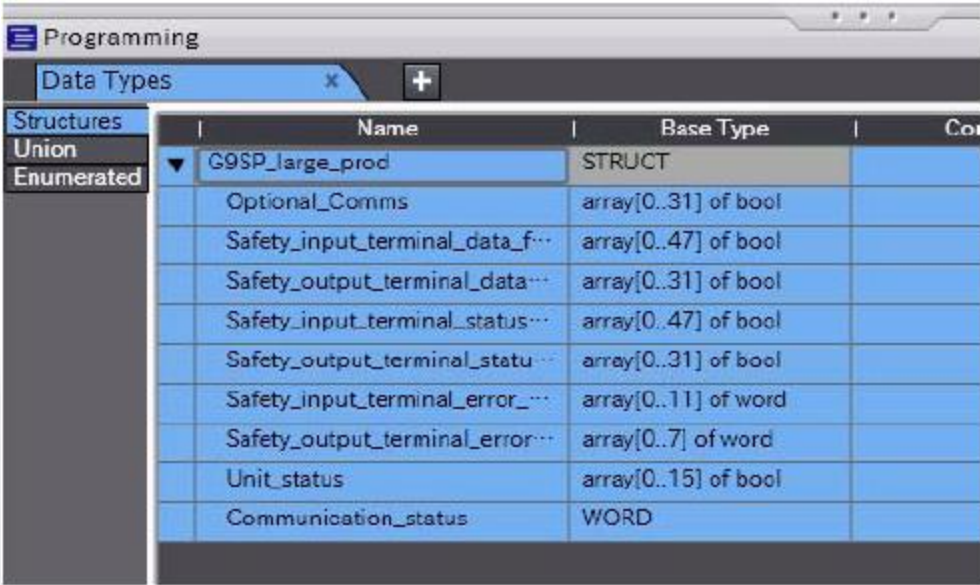

Setting up Tags In NJ5 Controller



- Repeat the last process for the Consumed Structures. The structures should look like this when you are done.

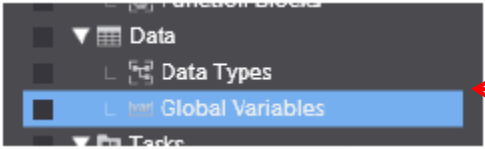

- Next, double click on **Global Variables** option in the project workspace.

- In the global variable window, **right click** and choose **Create New**. A new variable will be created.

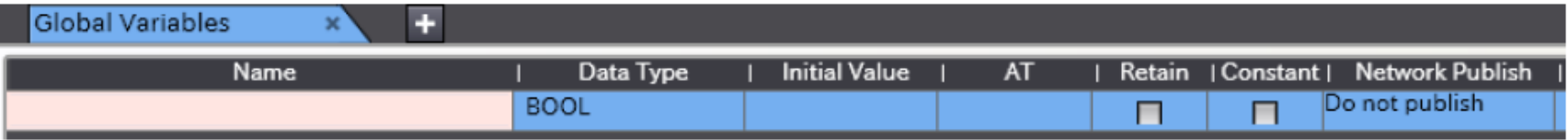

Setting up Tags In NJ5 Controller

- Give the variable a name and choose the structure name from the variable type. It is also necessary to define the tag as an input or output on the network. Do this 2 times, once for the produced variable and once for the consumed variable. The G9SP produced and consumed tags are shown below

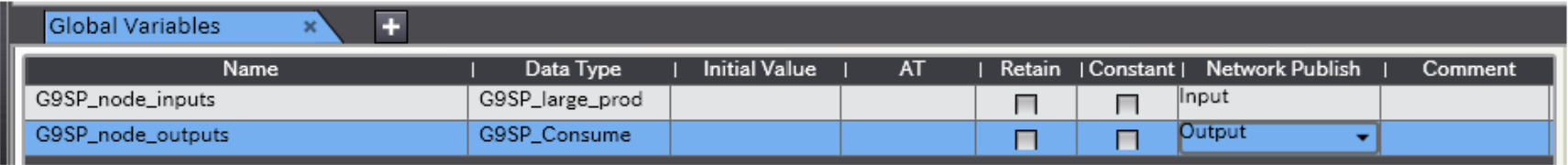

Name	Data Type	Initial Value	AT	Retain	Constant	Network Publish	Comment
G9SP_node_inputs	G9SP_large_prod			<input type="checkbox"/>	<input type="checkbox"/>	Input	
G9SP_node_outputs	G9SP_Consume			<input type="checkbox"/>	<input type="checkbox"/>	Output	

Notice that the G9SP produced information is named as an input for the tag creation. This is because when the G9SP produces data, it is consumed by the NJ5. Therefore, it acts like an input. The G9SP consumed information is produced (or output) by the NJ5, so the network publish type is set to output

- It is necessary to perform a synchronization as described earlier in this document to load the structures and tags into the controller



- The final step in this section is to export the tags for use in the network configuration software. To do this, select the tools pulldown menu, then choose Export Global Variables, then choose Network Configurator as shown

Install G9SP EDS File

Installing the G9SP EDS file in to network configurator software is necessary if never done before

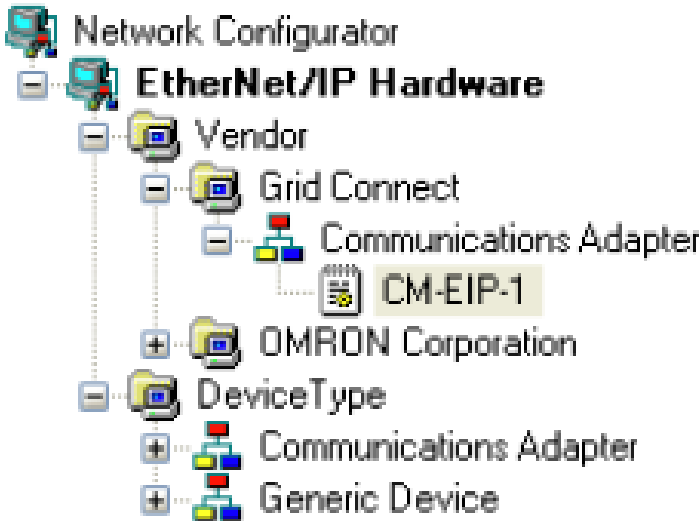

- Open the Sysmac Studio Network Configurator for EtherNet/IP.
- Choose the Install option from the EDS file pulldown menu and navigate to the CM-EIP-1.eds and select OK. Cancel the Icon installation.
- The CM-EIP-1 module should show up in the list of EtherNet/IP hardware as shown.

Configure EtherNet IP Network

To configure the Ethernet/IP connections to the NJ5 open Ethernet/IP Configurator software and create a new program for the NJ5

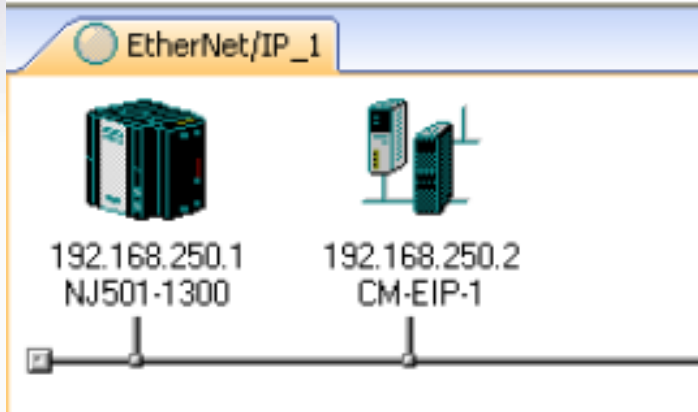

- Drag the NJ501-1300 and the CM-EIP-1 from the EtherNet/IP hardware list into your EtherNet/IP truck line in the Network Configurator as shown
- The IP addresses are automatically set as you add them to the network. Right click on each node and choose the **Change Node Address option**. Change the NJ5 to 192.168.250.1 and the CM-EIP-1 to 192.168.250.2 to match that were configured earlier in this document.

Configure EtherNet IP Network

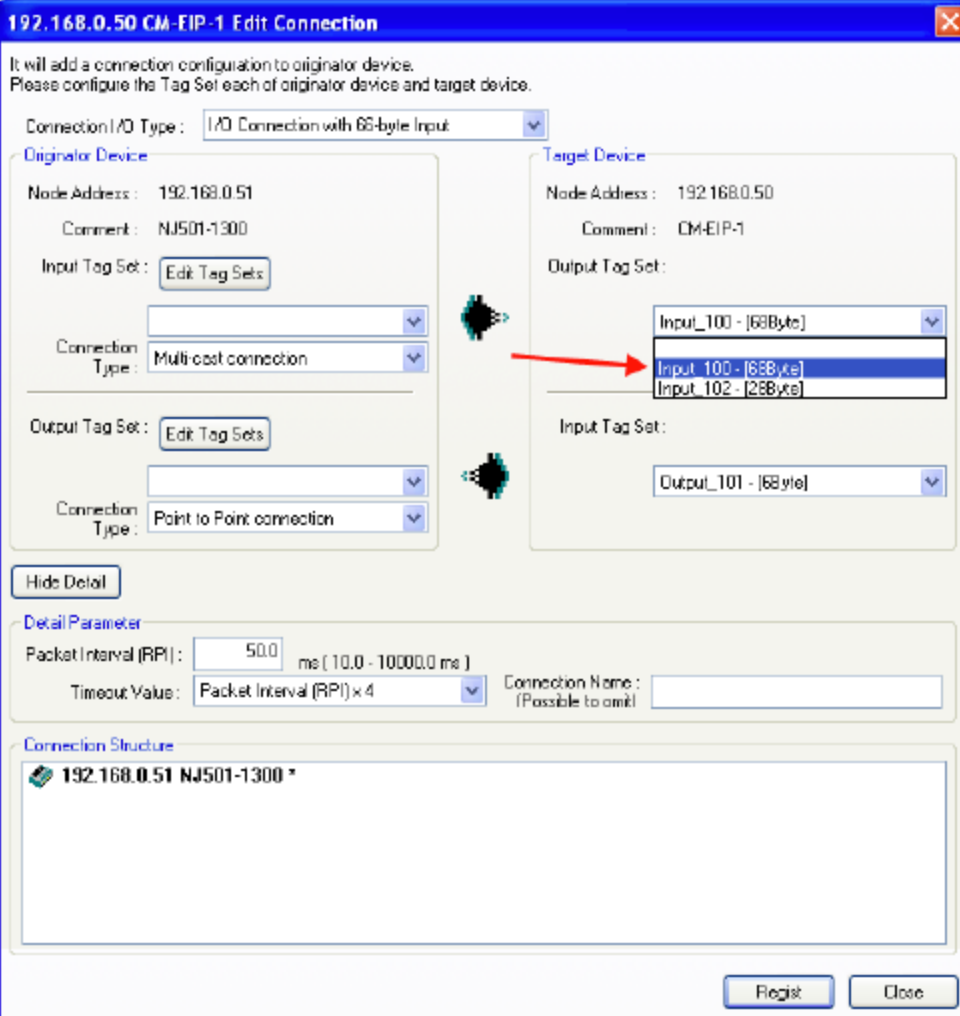

192.168.0.50 CM-EIP-1 Edit Connection

It will add a connection configuration to originator device.
Please configure the Tag Set each of originator device and target device.

Connection I/O Type: I/O Connection with 68-byte Input

Originator Device

Node Address: 192.168.0.51
Comment: NJ501-1300
Input Tag Set: Edit Tag Sets
Connection Type: Multicast connection

Target Device

Node Address: 192.168.0.50
Comment: CM-EIP-1
Output Tag Set: Input_100 - [68Byte]
Input Tag Set: Output_101 - [68byte]

Hide Detail

Detail Parameter

Packet Interval (RPI): 50.0 ms (10.0 - 10000.0 ms)
Timeout Value: Packet Interval (RPI) x 4 Connection Name: (Possible to omit)

Connection Structure

192.168.0.51 NJ501-1300 *

Register Close

- Click on the **Connection Tab**. The CM-EIP-1 module will show in the list of unregistered devices. Select **CM-EIP-1 module** and press the **down arrow** to move the adapter from the unregistered device list to the registered device list.
- Once the adapter is shown in the registered device list, **double click on adapter**, this window will appear.
- Make sure to select the 68 bytes inputs as shown by the red arrow

Configure EtherNet IP Network



- Match the tag names on the left hand side up with the input and the output assemblies on the right hand side. In this example, only one tag will be in the list for each of the connections. When done, the setting should look like this:

The screenshot shows two configuration panels. The left panel, titled 'Originator Device', has Node Address 192.168.0.51 and Comment NJ501-1300. Its Input Tag Set is 'G9SP_node_inputs - [68Byte]' and its Connection Type is 'Multi-cast connection'. The right panel, titled 'Target Device', has Node Address 192.168.0.50 and Comment CM-EIP-1. Its Output Tag Set is 'Input_100 - [68Byte]' and its Input Tag Set is 'Output_101 - [6Byte]'. Two network connection icons are shown between the panels.

- Press the **Register** button at the bottom of the window. The press **Close** button. Lastly press **OK** button on the **Edit Device Parameters** page.

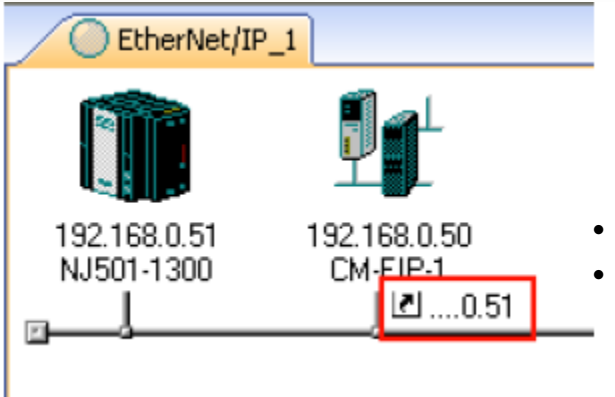

- The Network truck should look like this now.
- The arrow (highlighted in the red box) shows that the node is now connected to the NJ5

Down Loading EtherNet IP Network Configuration

- Connect the NJ5 to your computer using the USB cable
- In the Network Configuration software, choose the **Option Pull-down** menu then choose **Select Interface**, then choose **NJ Series USB Port.**,

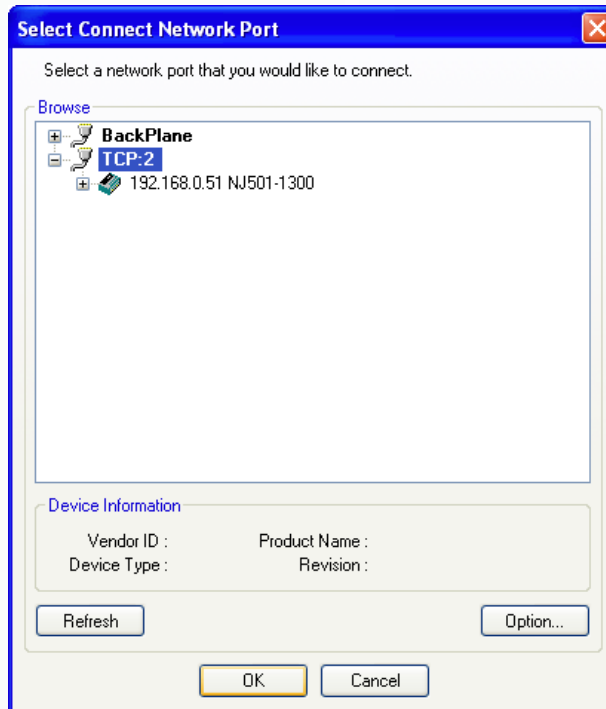

- From the **Network Pull-down** menu, choose **Connect**.
- Click on **TCP:2** and then press **OK**. Make sure to select the **Use Existing Network Option**.

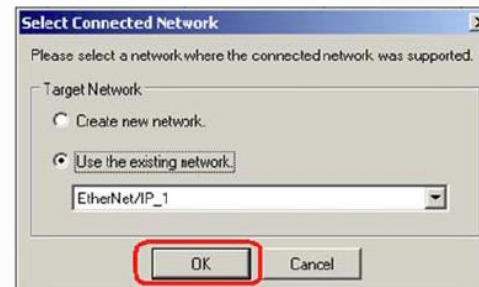

Down Loading EtherNet IP Network Configuration

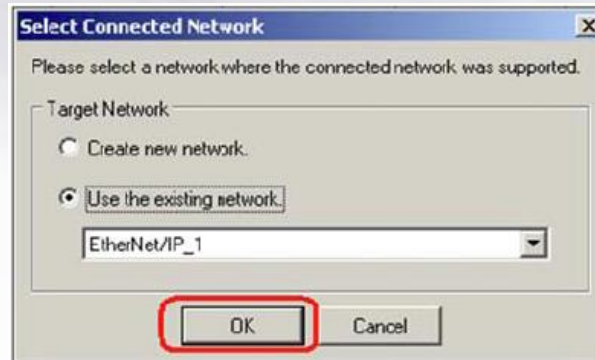

- Select **Use the existing network**, and click **OK**

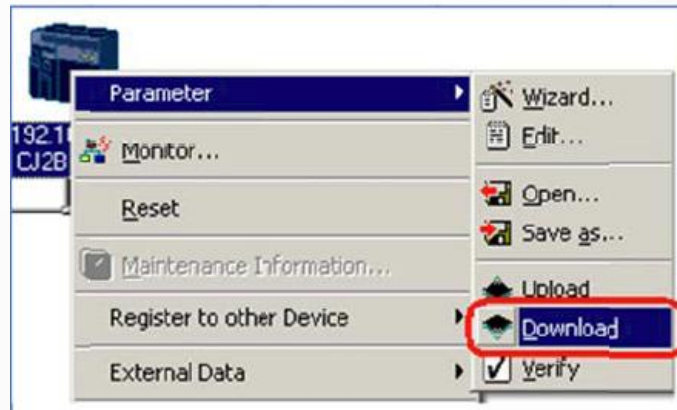

- From the **Network Pull-down** menu, choose **Download**

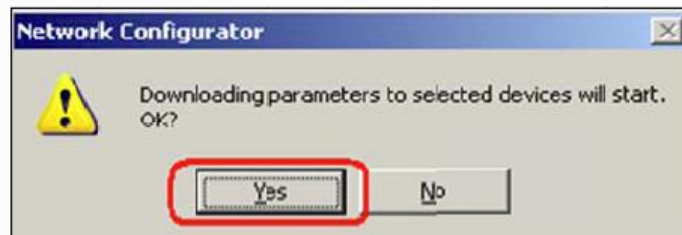

- Click **Yes** to download the parameters

Down Loading EtherNet IP Network Configuration

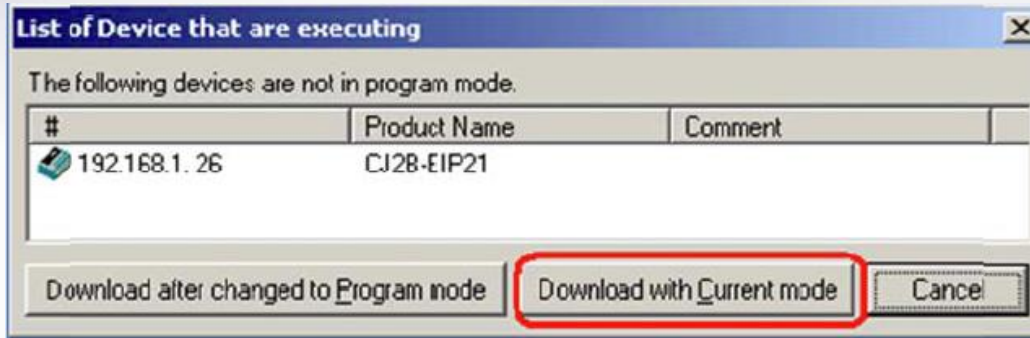

- To download to the EIP module without changing the PLC to Program mode, click **Download with Current Mode**



- When the download is complete, click **OK**

Testing Communications

At this point the network is configured and communication should be established. You can now use the optional communication reception and transmission data shown below in your function block programming.

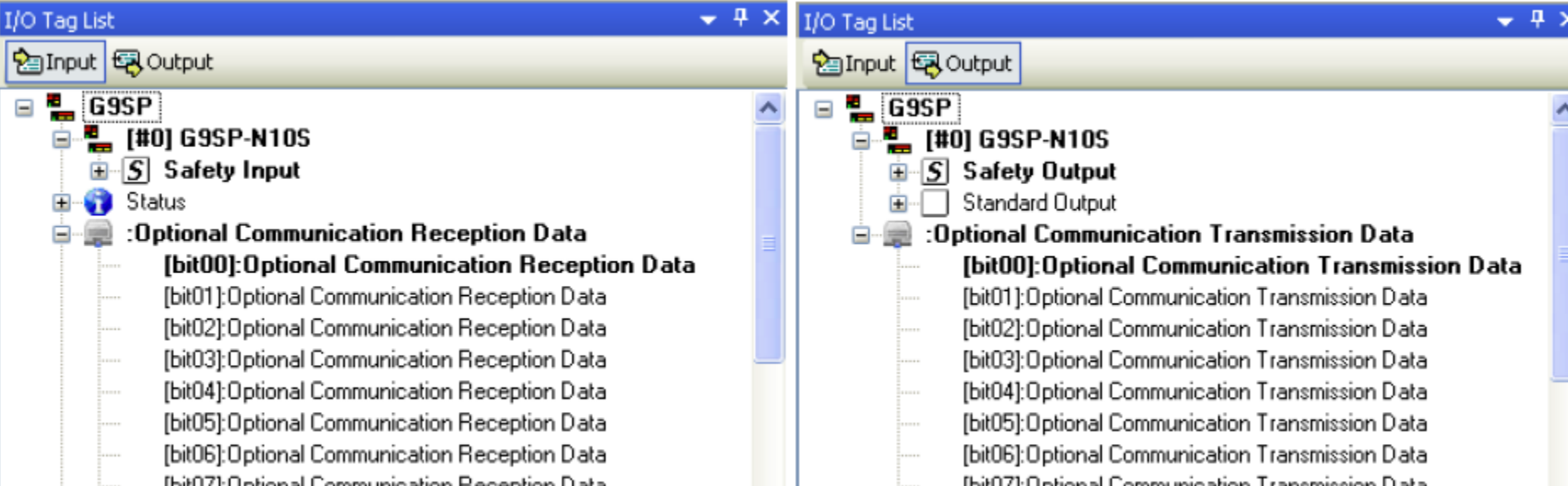

The image displays two side-by-side screenshots of the 'I/O Tag List' window in a software interface. Both windows show a tree view for a device named 'G9SP'. The left window shows the 'Optional Communication Reception Data' section, which includes bits [bit00] through [bit07], each labeled as 'Optional Communication Reception Data'. The right window shows the 'Optional Communication Transmission Data' section, which includes bits [bit00] through [bit07], each labeled as 'Optional Communication Transmission Data'. Both windows also show 'Safety Input' and 'Status' in the left window, and 'Safety Output' and 'Standard Output' in the right window.

I/O Tag List (Left Window):

- Input
- Output
- G9SP
 - [#0] G9SP-N10S
 - Safety Input
 - Status
 - :Optional Communication Reception Data
 - [bit00]:Optional Communication Reception Data
 - [bit01]:Optional Communication Reception Data
 - [bit02]:Optional Communication Reception Data
 - [bit03]:Optional Communication Reception Data
 - [bit04]:Optional Communication Reception Data
 - [bit05]:Optional Communication Reception Data
 - [bit06]:Optional Communication Reception Data
 - [bit07]:Optional Communication Reception Data

I/O Tag List (Right Window):

- Input
- Output
- G9SP
 - [#0] G9SP-N10S
 - Safety Output
 - Standard Output
 - :Optional Communication Transmission Data
 - [bit00]:Optional Communication Transmission Data
 - [bit01]:Optional Communication Transmission Data
 - [bit02]:Optional Communication Transmission Data
 - [bit03]:Optional Communication Transmission Data
 - [bit04]:Optional Communication Transmission Data
 - [bit05]:Optional Communication Transmission Data
 - [bit06]:Optional Communication Transmission Data
 - [bit07]:Optional Communication Transmission Data

Testing Communications

An example of a Safety Function Block program is shown below:

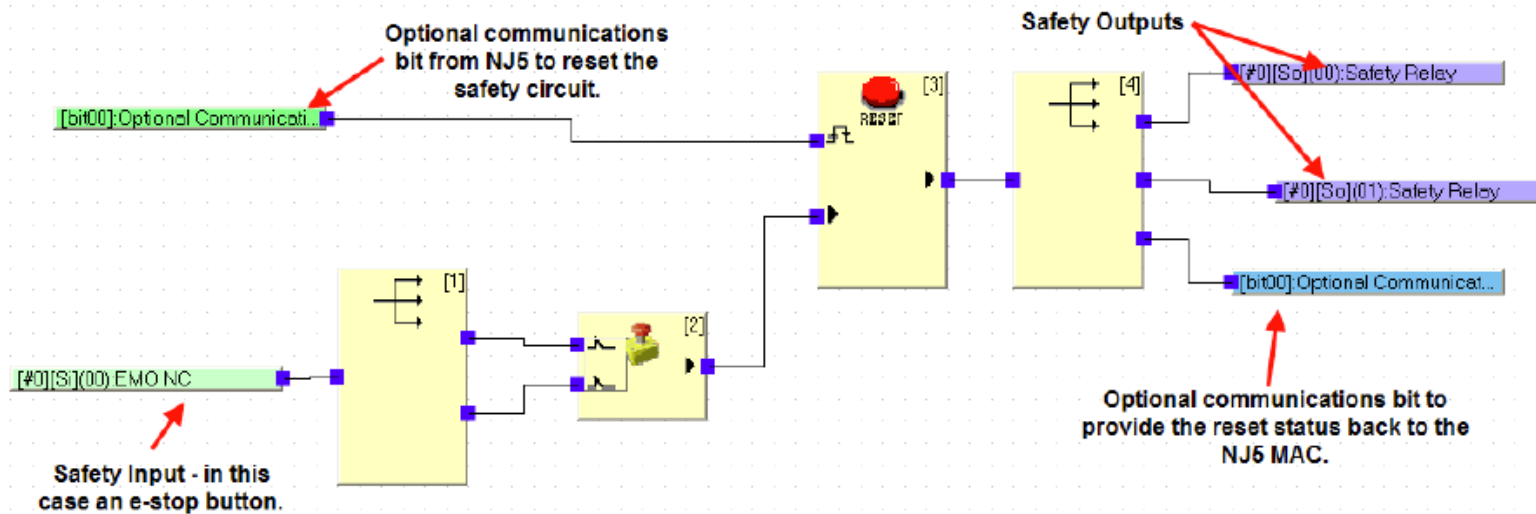

You can then use the tags in Sysmac Studio to write a program to use this information. An example is shown below:

